

## More Notes

# 3D ROCKETRY

## Ion Collector 3D Instructions



### Ion Collector 3D

- 1 - 2.5" Plastic Nose Cone
- 1 - 2" Plastic Boat Tail
- 1 - 15" BT-60 Body Tube
- 1 - 9" BT-60 Body Tube
- 1 - 6 1/4" X 24mm Motor Tube
- 2 - Fiber Centering Rings
- 3 - 3/16" Plywood Ring Fins
- 3 - 1/8" Plywood Main Fins
- 1 - 3/16" x 2" Launch Lug
- 1 - 3" x 3/4" Tail Ring
- 1 - 2" Tube Coupler
- 1 - 15" Mylar Parachute
- 1 - 2' Kevlar Shock Cord
- 1 - 3' x 1/4" Elastic Shock Cord
- 1 - 3- 3/4" Engine Hook
- 1 - Thrust Ring
- 1 - 1" Engine Spacer



3D Rocketry, Statement of Limitation of Liability

Limitation of Liability: Model rockets are not toys. Model rockets are functional rockets constructed of lightweight materials and launched using pre-manufactured, NAR safety certified model rocket motors in accordance with the NAR Model Rocket Safety Code. Model rockets, if misused, can cause injury, property damage and even death. 3D Rocketry certifies that it has exercised reasonable care in the design and manufacture of its products. Once sold, we cannot assume any liability for product storage, transportation or usage. 3D Rocketry shall not be held responsible for any property damage or personal injury whatsoever arising from the handling, storage, use or misuse of our product. The buyer assumes all risks and liabilities there from and accepts and uses 3D Rocketry products on these conditions.

# 3D ROCKETRY

## Step 1

**Optional Shock Cord Connection:** File a 1/16 in. x 1/16 in. notch in one of the centering rings as shown. This allows the shock cord to go through for gluing. Position front centering ring. (See Step 2) Next tie a large knot about 2-1/4 in. from the end of the shock cord this keeps the cord from pulling through. Glue 1-1/2 in. to 2 in. of the cord end to the motor tube as shown. Set aside to dry. (**Tip: Epoxy works best.**) Next file a 1/8 in. x 1/8 in. notch in second ring for motor hook.

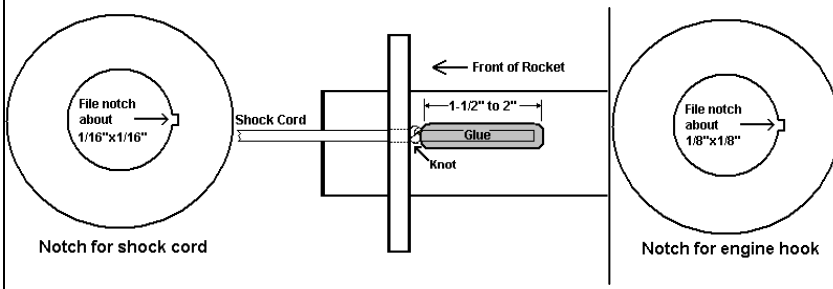

## Step 2

Glue forward centering ring to motor tube 5-7/8 in. from bottom of tube as shown. Be sure to pull shock cord through forward centering ring notch before gluing. (**Be sure to line up engine hook with shock cord on engine tube as to not interfere with fin attachment to motor tube.**) Cut a small slit in the motor tube 3-5/8 in. from rear of motor tube leaving 1/8 in. of engine hook overhanging. Apply a strong tape around motor tube and over the end of hook holding the motor hook in place as shown. (**Tip: Duct tape works great for engine hook attachment.**) Glue engine block in motor tube up to the engine hook as shown. Glue rear centering ring to motor tube 2-5/16 in. from bottom of tube as shown. Apply a few layers of fillet glue at the top of forward ring and bottom of rear ring as shown. Set assembly aside to dry.

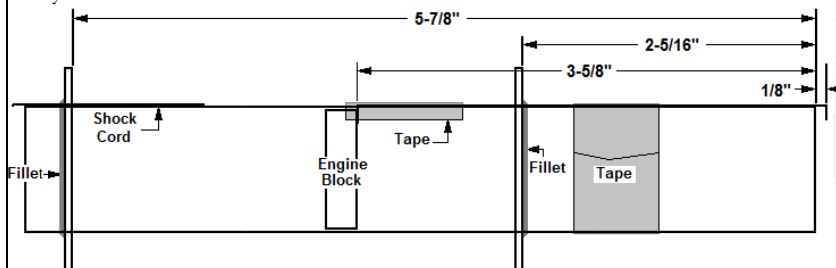

# 3D ROCKETRY

## Recommended Engines

(Estes) C11-3, D12-5, E9-6

(Aerotech) D9-5, D15-4, E30-7, E28-7, E15-7,

F12-5, E18-6, F24-7 and F39-6.

## Predicted Altitudes

250 Feet to 1,500 Feet

# 3D ROCKETRY

## Step 9

The nose cone weight has been adjusted to stabilize the rocket in flight so, DO NOT remove the nose weight. Tie parachute and nosecone as shown. Snap swivels can be used instead of tying directly to nose cone and parachute, this method makes removal much easier and chute can be used in another rocket. The nose cone and parachute connecting positions can be reversed per your preference. (TIP: A #5 snap swivel works nicely.)

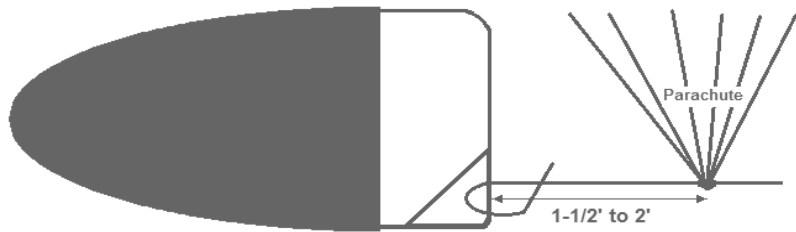

## Step 10

The 1" long spacer tube is provided to use 70MM long motors. ("D" single use motors and reloadable case motors.) The spacer tube must move freely inside the 24mm motor tube when it is being used!!

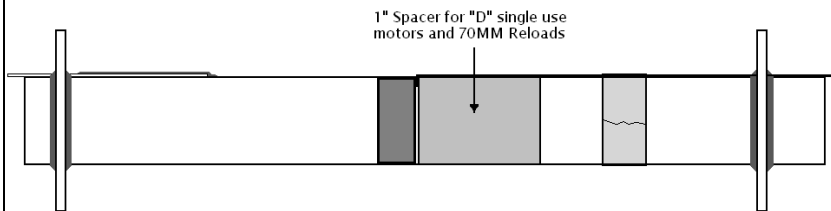

# ENJOY!!!

# 3D ROCKETRY

## Step 3

Cut out fin slot template guide, then cut out black slots with a sharp hobby knife and a straight edge. Tape slot guide around body tube lining it up with the small guide lines and end of body tube. Next tape fin guide at end of tube and at top of fin guide. The slots can be cut out a couple of different ways. 1) Trace slots with pencil or poke holes at each corner point and carefully cut out slots with a hobby knife freehand or with a straight edge. 2) trace slots and cut slots using a dremel type tool. After cutting slots sand or trim slots so fins slide through easily but snugly.

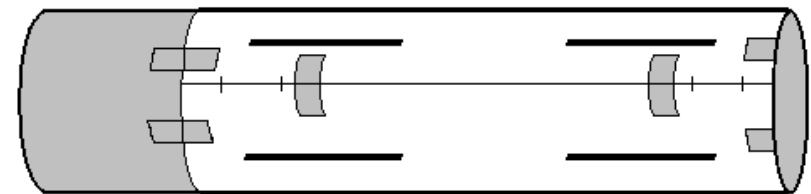

## Step 4

Glue the 2 in. long tube coupler 1" into the front of the lower body tube and glue the upper body tube over the coupler flush with lower body tube. (Some sanding of the coupler may be needed to get a good fit.)

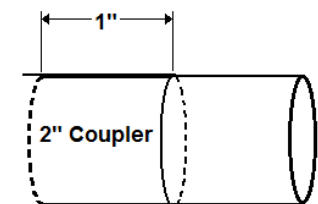

Find a scrap piece of stick that's about 6-8 in. long and mark the scrap piece at 3-3/4" in. Apply a generous ring of glue inside the main body

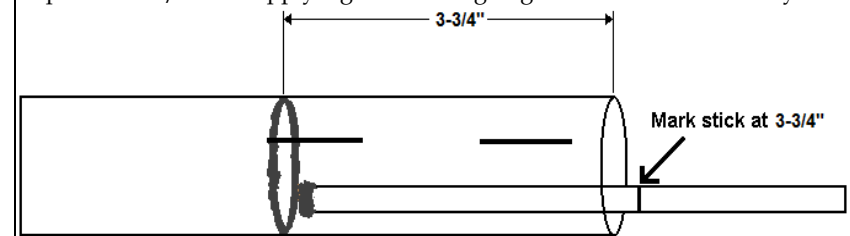

# 3D ROCKETRY

## Step 5

Insert the dry motor tube assembly into the main tube till the top centering ring is at the top of the forward fin slot. Stand up the completed assembly with the motor tube end down until the glue dries. Look down into body tube with flash light and check to make sure you have a good bead of glue around the outside of the centering ring.

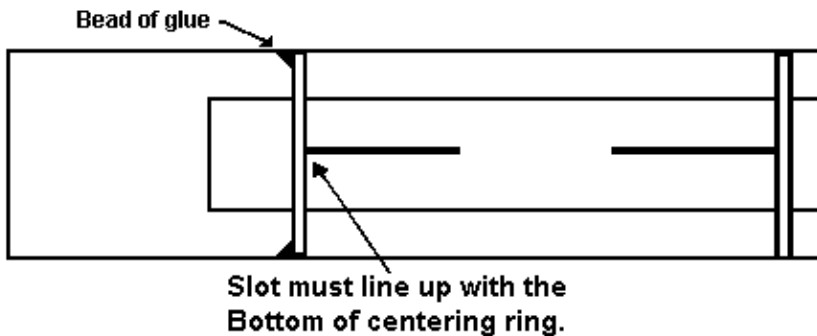

## Step 6

Sand root edge of ring fin to the curve of body tube. Sand the outer layer of tubing where the center fin will be attached, this allows adhesive to soak in to tube. **Optional step:** Use the tip of a hobby knife to create small holes in fin and body tube. Apply and push adhesive into holes on to both parts before attaching. Attaching the 3/16" thick ring fins like this gives a very strong bond.

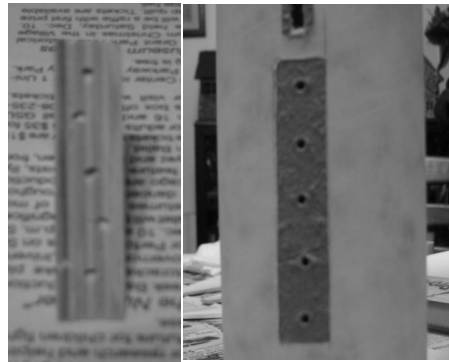
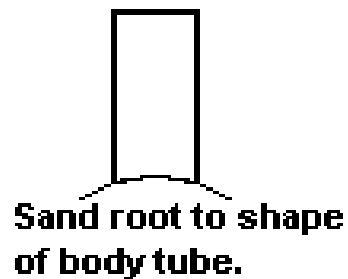

# 3D ROCKETRY

## Step 7

Step 1: Mark the centered location of the ring fins with supplied template. Sand the tube area (See Step 6) marked and glue each ring fin in place. **Let completely dry before step 2.** Step 2: Some sanding of ring fin top may be necessary for good ring fit. Sand top of the fin to the curved shape of the ring for a better fit. Adjust each fin equally until ring fits snug. One at a time, put main fins in slots but **do not glue** on yet. Glue ring into place as shown. Be sure ring will be centered between main fins. Step 3: Glue each main fin into place one at a time and check alignment with supplied finment with supplied finment. Step 4: Before gluing tail cone, cut a rectangular notch (1/8" W x 1/4" L.) in the tail cone as shown to allow the engine hook to go through and inserted.

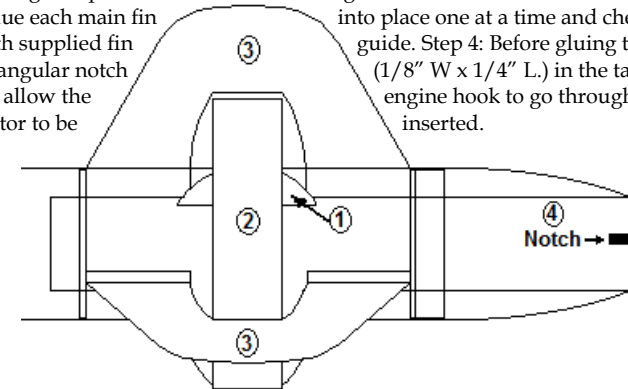

## Step 8

After all three sets of fins are dry, apply a few coats of fillets along the base of all of the fin sets as shown. Allow each layer of fillet to dry before reapplying. You can use your finger or a rounded tip stick to smooth out the fillets. Fillets greatly strengthen bonding of the fins to the main body tube.

After completely dry lightly sand fillets to smooth out imperfections.

